

PV IP54 Outdoor Cabinet 100kWh 2026 Model



PV IP54 Outdoor Cabinet 100kWh 2026 Model



100KWh Outdoor Cabinet Series Energy Storage System

100KWh LFP/SSB 3.2V/280Ah battery with over 8000 cycles at 70% DOD, ensuring stable long-term energy supply for commercial and industrial needs. IP54 protection + C4/C5 anti-corrosion grade, operating at ...

Sunway Intelligent Air Cooling 50kW 100kWh Outdoor Cabinet Energy

The Sunway 50kW/100kWh Outdoor Energy Storage System integrates high-performance lithium iron phosphate batteries, modular PCS, intelligent energy management, and a robust power distribution ...

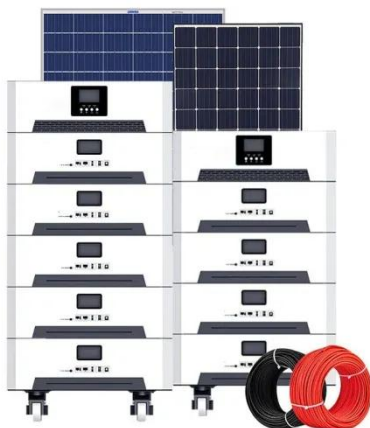

African PV IP54 Outdoor Cabinet 100kW

The intelligent air cooling system in the HighJoule 100KWh Outdoor Cabinet Series ensures optimal thermal management, maintaining battery efficiency and longevity.

100kwh ip54 photovoltaic battery cabinet

About 100kwh ip54 photovoltaic battery cabinet 100kwh ip54 photovoltaic battery cabinet represents a transformative advancement in the realm of energy solutions, particularly designed for industrial and ...

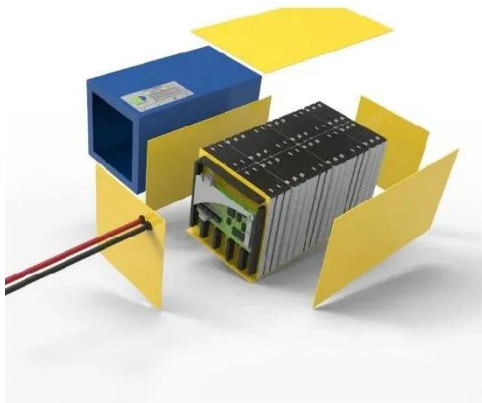

100KWh Outdoor Cabinet Series Energy Storage System

With an IP54 protection and C4/C5 anti-corrosion grade, it operates reliably in harsh environments. Ideal for solar microgrids, peak shaving, PV self-consumption, and emergency backup power, its modular design and ...

100 KWh-500KWh Solar Battery Storage Cabinet, 100kWh Battery Storage

This integrated solar battery storage cabinet is engineered for robust performance, with system configurations readily scalable to meet demands such as a 100kwh battery storage requirement.



50kW-100kWh Energy Storage

System Outdoor Cabinet Battery as ...



All-in-one 50kW/100kWh ESS cabinet for solar storage, backup, and peak shaving. Outdoor-rated, air-cooled, and easy to install with full EMS control.

100kWh Smart PV Ess Cabinet

Integrated PV and storage system with super wide PV input voltage; Small footprint and IP54 protecting grade for outdoor installation. Safe & Reliable High-performance battery cell, meet IEC/UL/GB standard; Advanced ...



High-Performance 50kW 100kWh Outdoor Cabinet Energy Storage ...

Enhance your energy storage capabilities with our cutting-edge 50kW/100kWh outdoor cabinet energy storage system. With a rated AC power of 50kW and a rated capacity of 100kWh, this system boasts a high system ...

50kW/100kWh Outdoor Cabinet Energy Storage System

It adopts door-mounted embedded integrated air conditioning, which does not occupy cabinet space, improves the available space of outdoor cabinets, has better structural integrity at the top, and has good waterproof ...

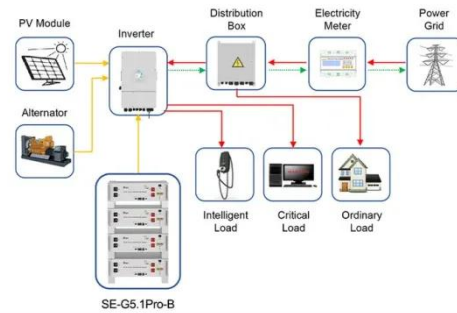

Application scenarios of energy storage battery products

Contact Us

For catalog requests, pricing, or partnerships, please visit:
<https://59empagm.pl>

