

Photovoltaic system energy storage principle and application



Principle and application:
PV energy storage system

Energy storage system



Overview

Solar energy storage technology works by converting solar energy into electrical energy and storing it in energy storage devices for use when needed. These variations are attributable to changes in the amount of sunlight that shines onto photovoltaic (PV) panels or concentrating solar-thermal power (CSP) systems. Solar energy production can be affected by season, time of day, clouds, dust, haze, or obstructions like shadows, rain, snow, and. This textbook provides students with an introduction to the fundamentals and applications of solar photovoltaic systems, connecting the theory of solar photovoltaics and the practical applications of this very important source of energy. The. eping the temperature of the system within critical values. In some cases, yes, having batteries for solar energy storage can be an important part of a system.

Photovoltaic system energy storage principle and application



Chapter 1: Introduction to Solar Photovoltaics - Solar Photovoltaics

Photovoltaic technology, often abbreviated as PV, represents a revolutionary method of harnessing solar energy and converting it into electricity. At its core, PV relies on the principle of the photovoltaic ...

Solar Energy Storage Technology: Principles, Applications, and the

Solar energy storage technology works by converting solar energy into electrical energy and storing it in energy storage devices for use when needed. The process begins with solar panels ...



Solar Integration: Solar Energy and Storage Basics

Sometimes energy storage is co-located with, or placed next to, a solar energy system, and sometimes the storage system stands alone, but in either configuration, it can help more effectively integrate ...



Photovoltaic Systems: Fundamentals and Applications

This textbook provides students with an introduction to the fundamentals and applications of solar photovoltaic systems, connecting the theory of solar photovoltaics and the practical applications of ...



Principle of Energy Storage Photovoltaic

The paper examines key advancements in energy storage solutions for solar energy, including battery-based systems, pumped hydro storage, thermal storage, and emerging technologies.

(PDF) Principles of solar energy storage

This paper overviews the main principles of storage of solar energy for its subsequent long-term consumption. The methods are separated into two groups, i.e., the thermal and photonic



Efficient energy storage technologies for photovoltaic systems



This review paper provides the first detailed breakdown of all types of energy storage systems that can be integrated with PV encompassing electrical and thermal energy storage systems.

Energy Storage Systems for Photovoltaic and Wind Systems: A ...

The hybrid energy storage combinations used in PV and wind systems are presented, detailing their advantages in terms of short-term and long-term energy storage, energy capacity, ...

WORKING PRINCIPLE

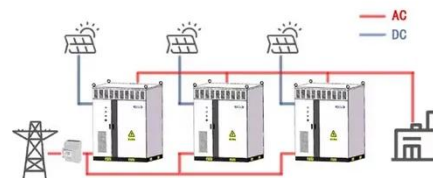

Principle and application of photovoltaic energy storage system

This chapter will briefly describe the principles and history of photovoltaic (PV) energy systems and will explore in details the various available technologies while reflecting on the

How does photovoltaic energy store itself? , NenPower

Once solar energy is converted into electricity, the next challenge lies in storing this energy for periods of low generation. Various technologies exist to accomplish this, each with distinct ...

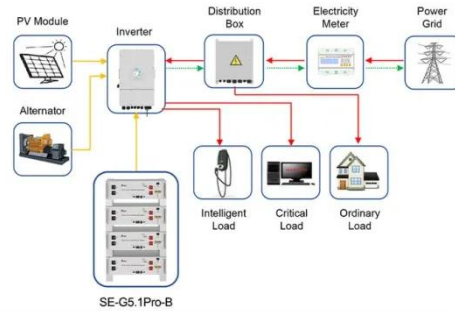

Application scenarios of energy storage battery products

Contact Us

For catalog requests, pricing, or partnerships, please visit:
<https://59empagm.pl>

